

MAINTENANCE-FREE MOTORCYCLE BATTERY

HPGU1R-4-P (12V25Ah)

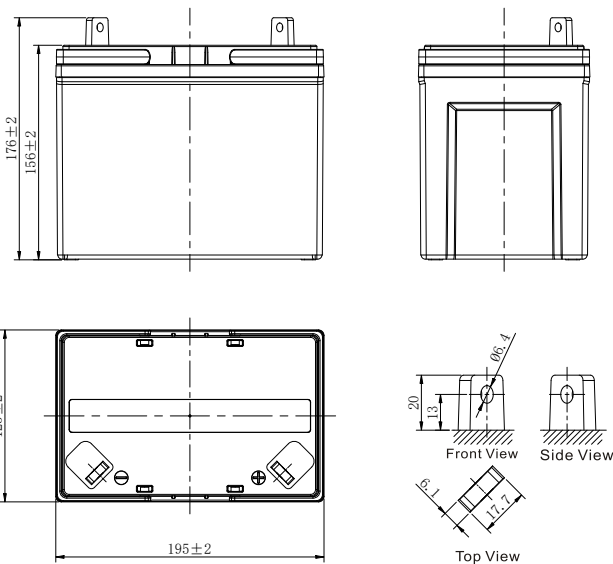

GENERAL FEATURES

- Maintenance-free
- Sealed and non-spillable AGM battery
- Shipped pre-charged and ready to install

*Values are subject to variation of +/- 5% in normal manufacturing processes.

CHARACTERISTICS

Item	Specifications	
Nominal Voltage	12V	
Nominal Capacity (10HR)	25Ah	
Cold Cranking Performance Amps@0°F (-18°C)	320A	
Dimension (±2mm)	Length	195mm (7.68inches)
	Width	125mm (4.92inches)
	Container Height	156mm (6.14inches)
	Total Height	176mm (6.93inches)
Battery (with acid)	Approx Weight	8.34kg (18.4lbs)
Terminal type	G	
Battery type	Factory Activated Series	
Full Charge	Constant-Voltage Charge:	
	Initial charging current	Less than 0.3C ₁₀
	Voltage	14.40V~15.00V at 25°C (77°F)
	Charging time	15~18h
	Constant-Current Charge:	
	Charging current 0.1C ₁₀ , when charging voltage up to 14.40V, continue to charge 4h	
Floating Charge	Initial charging current	Unlimited
	Voltage	13.50V~13.80V at 25°C (77°F)
Capacity affected by Temperature	40°C (104°F)	106%
	25°C (77°F)	100%
	0°C (32°F)	86%
	-15°C (5°F)	65%

Discharge Characteristics (25°C, 77°F)

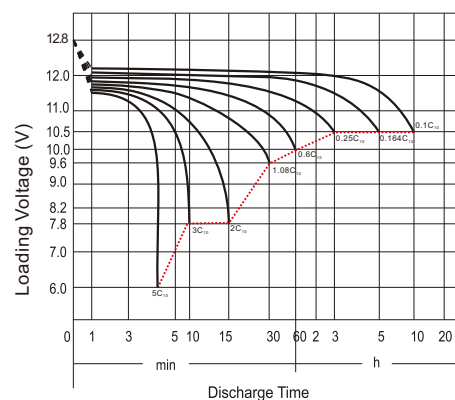

Leoch International Technology Ltd.
www.leoch.com

Leoch Batteries Pte Ltd
www.leoch.sg

Leoch Battery Corporation
www.leochamericas.com

Leoch Europe S.A.
www.leoch.eu